

**Owner** O'TOOLE, COLLEEN MARY  
**Address** 276 LEGEND LN  
 HIGHLAND HEIGHTS, OH. 44143  
**Land Use** (5100) R - 1-FAMILY PLATTED LOT  
**Legal Description** SL 17 VOL 360 PGS 40-42 FF 46.00 D 122.63 .1295AC OL 13 THE LEGENDS @ ABERDEEN SUBDIVISION PHASE 4 2010S/R  
**Neighborhood Code** 13315

**SKETCH**

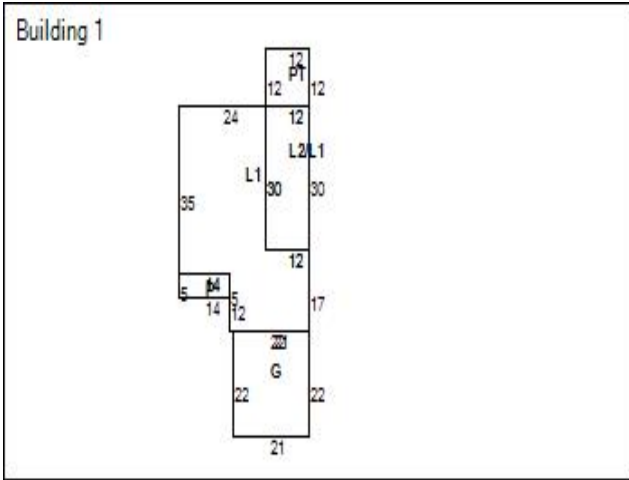

**MAP VIEW**



**BUILDING INFORMATION**

Building Record Number	1	Occupancy	1-FAMILY	Story Height	2
Style	TOWNHOUSE	Year Built	2009	Exterior Walls	ALUM/VINYL
Condition	GOOD	Construction Quality	B+ / GOOD+	Roof Type	GABLE
Roof Material	ASPH-SHINGLE	Heat Type	FORCED-AIR	Air Conditioning	CENTRAL
Attic Type	NONE	Basement Type	SLAB	Basement Square Feet	
Basement Finished	N/A	Rooms	7	Bedrooms	3
Bathrooms (Full/Half)	2/0	Garage Type	ATTACHED	Garage Capacity	2
Year Garage Built	2009	Garage Size	462	Living Area Basement	
Living Area 1	1,524	Living Area 2	360	Living Area Upper	
Living Area Total	1,884	Floor Location		Party Wall	Y

**LAND**

Code	Frontage	Depth	Acreage	Sq Ft
PRM	46	123	0.13	5,641

**VALUATION**

2022 Values	Taxable Market Value	Exempt Market Value	Abated Market Value	Assessed Taxable Value
Land Value	\$75,000	\$0	\$0	\$26,250
Building Value	\$217,000	\$0	\$0	\$75,950
Total Value	\$292,000	\$0	\$0	\$102,200
Land Use	5100			SINGLE FAMILY DWELLING

**PERMITS**

Tax Year	Reason	Tax Change	Exempt Change	Percent Complete	Reinspect	Notes
2011	30 - New Construction	\$101,100	\$	100%	No	NEW DWELLING 100% COMPLETED 1-1-2011 VALUE ADDED \$101,100.00
2010	130 - Sub register	\$53,000	\$	100%	No	2010 S/R
2010	30 - New Construction	\$68,500	\$	40%	Yes	NEW DWELLING 40% COMP 1-1- 2010 VALUE ADDED +68,500 RNSPCT2011
2010	70 - Change of class	\$	\$	100%	No	CLASS-CHANGE 2010

**IMPROVEMENTS**

Type	Description	Size	Height Depth
------	-------------	------	--------------

**SALES**

Date	Buyer	Seller	Price
6/25/2021	O'TOOLE, COLLEEN MARY	STELLA, DEBRA A.	\$344,000
11/19/2015	STELLA, DEBRA A.	STRANO, HOLLIE A. TRUSTEE	\$240,000
3/28/2011	STRANO, HOLLIE A. TRUSTEE	STRANO, HOLLIE A. TRUSTEE	\$0
8/27/2010	STRANO, HOLLIE A. TRUSTEE	THE LEGENDS BUILDING CO LTD	\$228,000
10/6/2009	THE LEGENDS BUILDING CO LTD		\$0

**Taxes**

2022 Taxes	Charges	Payments	Balance Due
Tax Balance Summary	\$6,853.96	\$3,426.98	\$3,426.98